

CRN Series

REFRIGERATED COMPRESSED AIR DRYERS
10-3000 SCFM

- ▶ ISO Quality Class Performance
- ▶ Integral Filtration
- ▶ Stainless Steel Brazed Plate Heat Exchangers

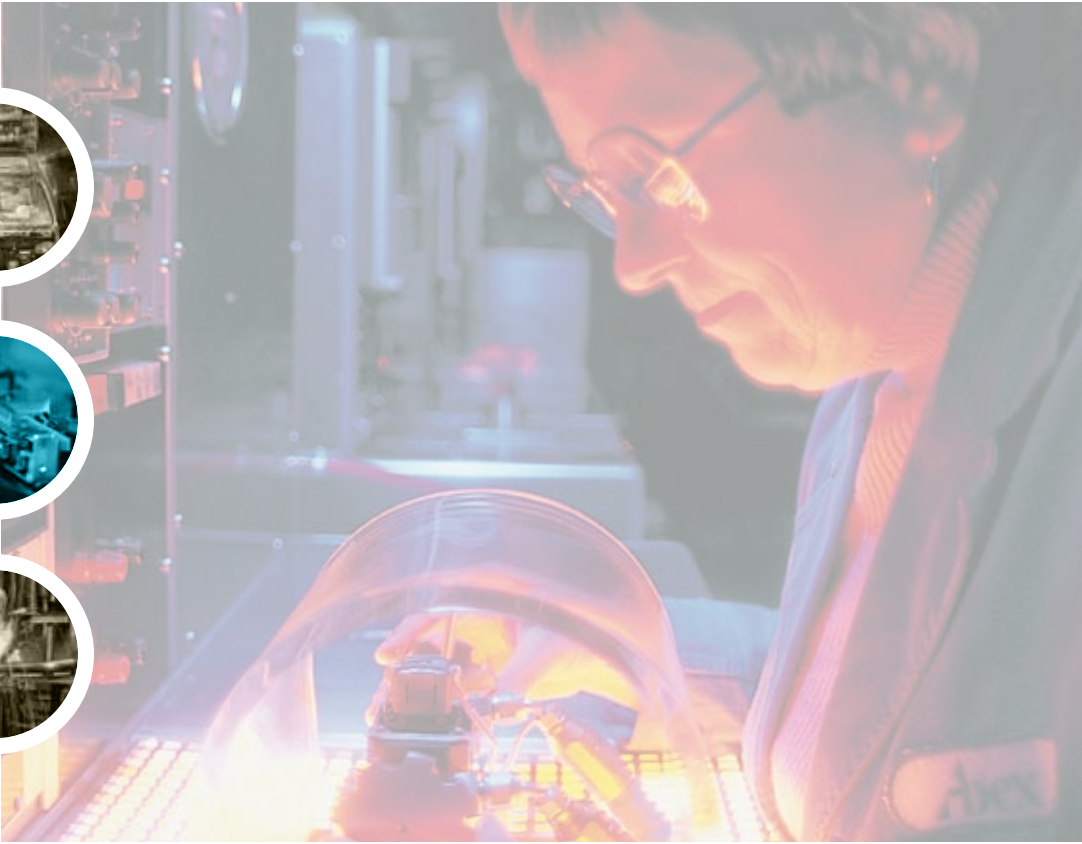

CHAMPION[®]

Durability Delivered

CRN SERIES REFRIGERATED AIR DRYERS



CRN Series refrigerated air dryers are engineered to benefit you today and tomorrow from the tradition of durability that is Champion. Quality components and engineering excellence meld to ensure you of a stable ISO Quality Class 4–5 pressure dew point. These exclusive compressed air preparation packages combine reliability, cutting-edge design, and innovative packaging into a single space saving unit. The air quality delivered from an CRN Series dryer may define the difference between moderate and superior results from your plant's processes or systems.

CRN Series dryers benefit you with:

- 1 Four levels of Intelligence Controller (I-Controller) packages to allow you to customize the CRN Series dryers to meet your specific requirements. This lets you choose which I-Controller package represents your best value.
- 2 Select Heat Exchanger arrangements to ensure you get the right combination of value and efficiency in every size. This secures your investment today and tomorrow with energy efficiency and the best warranties in the industry.
- 3 Combination Separator/Filter that incorporates our 99% efficient 3 micron Grade B elements. This ensures you of consistent water removal (especially under low flow conditions).

AIR TREATMENT SYSTEMS

The flexibility engineered into every CRN Series dryer allows you to satisfy your air quality requirements with a single package. Enlist us to deliver the dew point stability, air quality, energy efficiency, and product reliability that you expect from Champion.

ISO 8573.1 AIR QUALITY CLASSES

1992 earmarked the year the International Organization for Standardization (ISO) established ISO 8573.1 as the global benchmark for evaluating the quality of compressed air. Thus, providing engineers with a universally accepted unit of measure for quantifying compressed air stream contaminants. Namely Solid Particulates, Moisture, and Oil.

STANDARDS PER ISO 8573.1

Quality Classes	Solid Contaminants (maximum particle size in microns)	Max. Pressure Dew Points °F (°C)	Maximum Oil Content (droplets, aerosols, & vapor ppm w/w (MG/M ³))
0	as specified	as specified	as specified
1	0.1	-94 (-70)	0.008 (0,01)
2	1	-40 (-40)	0.08 (0,1)
3	5	-4 (-20)	0.8 (1)
4	15	38 (3)	4 (5)
5	40	45 (7)	21 (25)
6	-	50 (10)	-

CRN Series packages deliver:

ISO 8573.1 QUALITY CLASS RATINGS

CRN Seriesw	Solids	Moisture	Oil
As Standard	3	4–5	5
with Cold Coalescer Option	1	4–5	1
with an optional external Grade G CFF Filter (shown attached)	1	4–5	0*

*Quality Class 0 reflects "as specified" level of cleanliness. The addition of an optional external Grade G Filter achieves 0.003 ppm w/w for technically Oil-Free air.



Built to Perform



Extended Warranty available: contact your local distributor for more details.

PACKAGE DESIGN

At first glance, the ruggedness and ease of serviceability engineered into CRN Series becomes apparent. Fabricated from solid steel, the corrosion resistant epoxy powder paint and the fit and finish of the cabinet, foretell of the quality to be found within. At the touch of a button, quick fasteners release each lift out door panel. Easy interior access and user-friendly serviceability translate to reduced maintenance costs.

PROVEN PERFORMANCE

All models use reliable refrigeration compressors and environmentally friendly refrigerants. Models through CRN500 use proven reciprocating refrigeration compressors. CRN600 through CRN3000 incorporate rugged scroll compressors. You benefit from long component life, and exceptional around-the-clock performance.

CRN 10-15

The patented static condenser technology eliminates the need for a cooling fan. Models include an on/off power switch, 8 foot power cord and no air loss float drain. Outlet air is reheated to eliminate pipe line sweat.

HEAT TRANSFER

CRN models 10-15 benefit from our smooth handcrafted all copper heat exchangers. Multiple tube-on-tube designs achieve the low pressure drop, high heat transfer.

CRN Series models 25-300 incorporate heat exchangers crafted from multiple offset layers of press formed AISI 316 stainless steel. Press forming creates peaks and valleys that form media channels that are rich in fluid turbulence. This prevents fouling and maximizes energy efficiency.

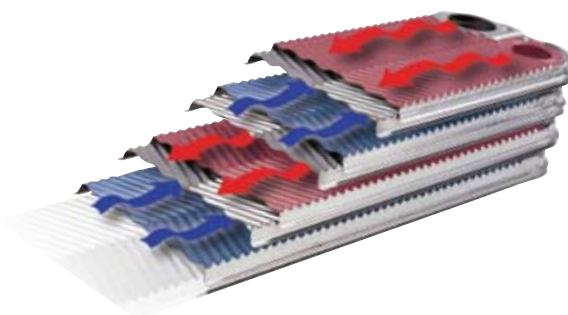

MAXIMUM EXTRACTION SEPARATOR/FILTER

Effective moisture removal at all flow rates is the key to preserve dew point stability. CRN25 and larger includes Grade B two-stage cold filtration to ensure maximum water extraction even under low flow conditions. Stage one mechanically entraps solids >10 microns with dual stainless steel orifice tubes. Stage two utilizes in-depth fiber media to coalesce water droplets and retain solid particles 3 microns and larger.

GET CONNECTED

The extended inlet/outlet connections on CRN dryers (CRN25-CRN750) were engineered with foresight to readily accept all CFF Series Filters without the need for cumbersome adaptors and fittings. CRN1000 - 3000 inlet/outlet connections on top of unit for ease of installation. You gain the installation flexibility you need today that may help you be prepared to meet the changes of tomorrow.



Take Control



CRN Series dryers are equipped with control schemes that are designed to provide you with the most value delivered within each flow range. Engineered with industry leading features, each I-Controller package provides just the right level of benefits to appeal to the most demanding applications and discriminating customers.

INSTRUMENTATION

Power-on LED and 6 foot grounded power cord are standard on all single-phase 115-volt units. Easy view angular instrumentation panels prominently display all I-Controllers instrumentation packages



I-CONTROLLER LEVEL 1

On/Off rocker switch, green power on light, temperature indicator and pneumatic, pilot-operated drain trap. Easy to monitor display panel.



I-CONTROLLER LEVEL 2

Standard equipment* on models CRN125 through CRN750 includes: "Power-on" LED, "Compressor-on" LED, On/Off rocker switch, dew point bar graph LED display. Timed solenoid drain trap with push-to-test button and secondary manual drains complete with by-pass valves and drain lines are standard equipment. This helps keep the surrounding area clean and dry and helps you avoid having to shutdown the dryer during drain valve maintenance. Upgrade to I-Controller Level 2 optional on CRN25-CRN100.

Compare these Features— Unmatched in the Industry!

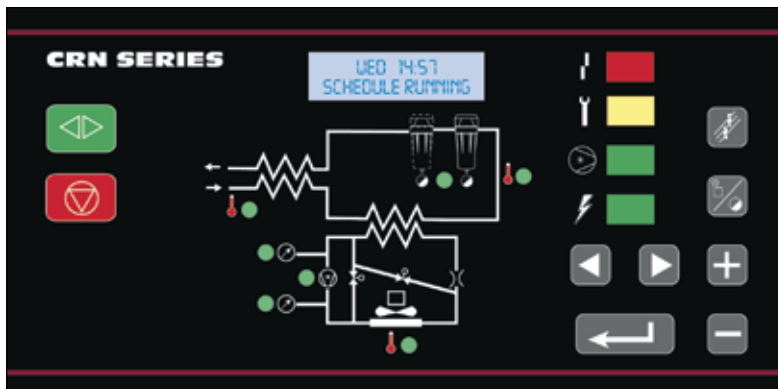

I-CONTROLLER LEVEL 3

Optional equipment on models CRN200 through CRN750 includes: LED indicated process diagram, remote start/stop, compressor run time, °F/°C selectable temperature readings for Inlet Air, Dew Point, and Ambient Air. Vivid yellow LED to advise when scheduled maintenance is due, and warn if high ambient or inlet air temperatures warrant attention. Alarm Mode triggers a bright red LED, dry contacts for high dew point remote alarm at 55°F. Downloadable memory stores details of the last 10 alarm events (e.g., date, time, fault.) English, Spanish, French language selectable. Demand Drain with push-to-test button and secondary manual drains complete with by-pass valves and drain lines are standard equipment. This helps keep the surrounding area clean and dry and helps you avoid having to shutdown the dryer during drain valve maintenance.

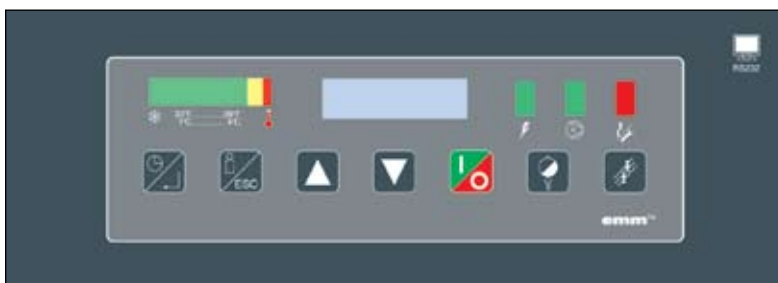

I-CONTROLLER LEVEL 4

Standard equipment on models CRN1000 through CRN3000 includes: manual mode, schedule mode to synchronize operation to your workday, auto restart, text display window that displays current time, operating mode, total operating hours, hours to service, dew point bar graph LED display, initializes alarm relay, display, compressor-on light, power-on light, temperature indicator, alarm/service light, reset button, set/run button, programming buttons, on/off button, drain push-to-test button, English, Spanish, German, French and Italian language selectable, RS-232 communication capable, fault condition diagnostics with text display, dry contacts for high dew point remote alarm at 55°F.



Refrigeration Circuit

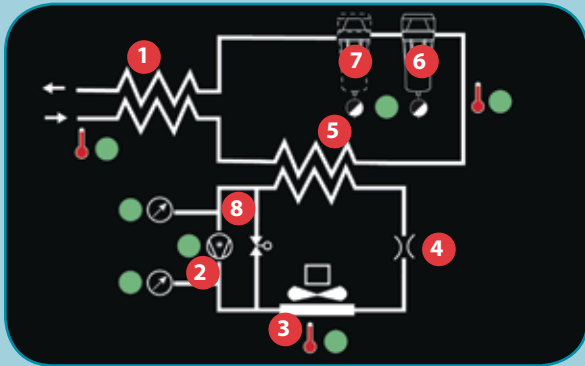

- Precooler/Reheater **1**
- Refrigeration Compressor **2**
- Condenser **3**
- Thermal Expansion Valve **4**
- Evaporator **5**
- Moisture Separator/3 micron Filter **6**
- Optional Cold Coalescing Oil Removal Filter **7**
- Suction-side **8**

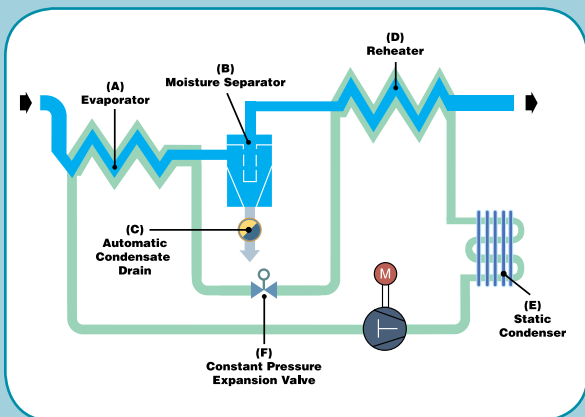

- Evaporator **A**
- Moisture Separator **B**
- Automatic Drain **C**
- Reheater **D**
- Static Condenser **E**
- Constant Pressure Expansion Valve **F**

CRN 25-3000

Series dryers enlist proven components and modern materials to deliver the durability you expect from Champion. Hot, moist incoming compressed air enters the Precooler/Reheater **(1)** where it is pre-cooled by the cold dehydrated airstream. Environmentally friendly low-pressure refrigerant gas is pressurized in the refrigeration compressor **(2)**. Once compressed into a high-pressure gas, it then flows through the condenser **(3)** and changes to a cold 35°F liquid. The thermal expansion valve **(4)** precisely meters the cold liquid refrigerant into the evaporator **(5)** where the work is done. Hot, saturated compressed air enters the evaporator at the end opposite the incoming liquid refrigerant. The compressed air is chilled as they cross paths. Water is condensed out of the cold exiting air and is efficiently removed in the Separator/3 micron Filter **(6)**. The cold air stream then flows through **(7)** the Cold Coalescing Oil Removal Filter (optional on models CRN25–CRN3000) where oil droplets and aerosols to 0.008 ppm w/w are captured and removed. The exiting cold, dry compressed air then reenters the Precooler/Reheater **(1)** where it is reheated by the hot incoming air to prevent pipe sweating in your plant. Finally, the warm refrigerant is now a low-pressure gas and returns to the suction-side **(8)** of the refrigeration compressor to continue the process.

CRN 10-15

Warm saturated air enters the Evaporator **(A)**, where it is cooled by an air-to-refrigerant process. Water vapor condenses into a liquid for removal at the moisture separator **(B)** by an Automatic Drain **(C)**. The cold, dry air is reheated as it passes through the Reheater **(D)** while the patented Static Condenser **(E)** radiates waste heat to ambient. This eliminates the need for a cooling fan and prevents pipeline sweating at the air outlet.

A Constant Pressure **(F)** Expansion Valve (CPEV) modulates the flow of liquid refrigeration to the Evaporator **(A)**. This eliminates freeze-ups and assures continuous, automatic dew point control. The CPEV responds to pressure changes as the refrigerant leaves the Evaporator. This maintains the proper cooling rate under all load conditions. The CPEV is adjusted at the factory to deliver automatic operation.

System Options

INSTRUMENTATION

Power-on LED and 6 foot grounded power cord are standard on all single-phase 115-volt units. Easy view angular instrumentation panels prominently display all I-Controllers instrumentation packages.

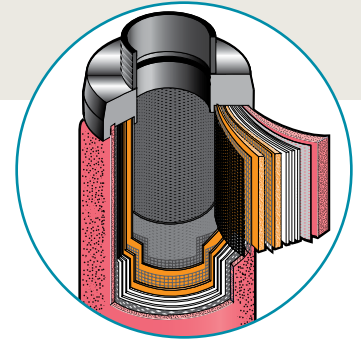

OPTION FEATURE OVERVIEW

Control Version	LED Indicator lights			Drain Valves			System Upgrades	
	Power-on	Compressor-on	Dew Point Temperature Indicator	Pneumatic Pilot-Operated	Timed Drain w/ Push-to-test*	Demand Drain w/ Push-to-test*	Cold Coalescing Oil Removal Filter	Vacuum Fluorescent Text Display
I-Controller Level 1	S	S	S	S	-	-	0	-
I-Controller Level 2	S	S	S	-	S	-	0	-
I-Controller Level 3	S	S	-	-	-	S	0	S
I-Controller Level 4	S	S	S	-	-	S	0	S

S = Standard Feature

O = Optional Feature

* Secondary manual drains complete with by-pass valves are standard equipment and only available on packages with Level 2, Level 3, and Level 4 I-Controllers. This helps keep the area clean and dry and helps you avoid dryer shutdown during drain valve maintenance.

OIL REMOVAL... this option integrates our factory installed Grade E Cold Coalescing Oil Removal Filter. Oil droplets and aerosols are extracted from the air stream in cleaning it down to 0.008 ppm w/w and solids are retained down to 0.01 micron. CRN Series dryers that include the Cold Coalescing Oil Removal Filter option are also equipped with a dedicated drain trap. Drain trap is consistent with the type provided with your chosen I-Controller. Available on models CRN25–CRN3000.

LOW AMBIENT... this option protects the dryer from internal damage due to freezing temperatures down to -10°F. Factory installed package includes heat tracing, thermostat and insulation for separator bowl.

GAUGES... four panel mounted gauges: air inlet temperature, air outlet pressure, refrigerant suction pressure and refrigerant head pressure.

DRY CONTACTS... remote bulb temperature switch with "C"-form contacts; mounted inside cabinet.

AIR-BYPASS PIPING... Three valve block and bypass; mounts to inlet/outlet connections; shipped loose. MWP 200 psig



CRN SERIES REFRIGERATED DRYER-FILTER SPECIFICATIONS

Model CRN	Rated Flow (1)	Standard I-Controller (2)	Connection [inches] (3)	Dimensions [inches]			Weight [lbs]	w/Oil Remo R [lbs]	Voltages [v/ph/Hz]	kW	Dryer Model Number	Kits for Dryers Mfg. Before June 15, 2006	Kits for Dryers Mfg. After June 15, 2006
				H	W	D (4)							
10 15	10 15	n/a	3/8 OD 3/8 OD	15 15	12.6 12.6	12.6 12.6	64 69		115/1/60	1/7 1/7	CRN 25, 35 CRN 25, 35 w/ OPTION F CRN 50	CRNМК2 CRNМК12 CRNМК3	CRNМК2 CRNМК12 CRNМК3
25 35 50 75 100	25 35 50 75 100	I-Controller Level 1	1/2 NPT 1/2 NPT 1/2 NPT 3/4 NPT 1 NPT	26 26 26 26 38	20.5 20.5 20.5 20.5 29	18 18 18 18 20	86 90 95 106 251	147 151 157 216 258	115/1/60 208-230/1/60 220-240/1/50	.21 .25 .41 .59 .93	CRN 50 w/ OPTION F CRN 75, 100 CRN 75, 100 w/ OPTION F CRN 100 CRN 100 w/ OPTION F CRN 125, 150 CRN 125, 150 w/ OPTION F CRN 200, 250 CRN 200, 250 w/ OPTION F CRN 300	CRNМК13 CRNМК4 CRNМК14 N/A N/A CRNМК5 CRNМК15 CRNМК6 CRNМК16	CRNМК13 SEE BELOW SEE BELOW CRNМК22S CRNМК42S CRNМК23S CRNМК43S CRNМК24S CRNМК44S
125 150 200 250 300 400 500 600 750	125 150 200 250 300 400 500 600 750	I-Controller Level 2	1 NPT 1 NPT 1-1/2 NPT 1-1/2 NPT 2 NPT 2-1/2 NPT 2-1/2 NPT 2-1/2 NPT	38 38 39 39 46 46 58 58 58	29 29 34 34 35 35 32 32 32	20 20 32 32 32 42 42 42	273 279 425 463 527 571 684 646 734	281 287 438 476 540 603 716 691 804	208-230/3/60 460/3/60 575/3/60 575/3/60 380-420/3/50	1.28 1.30 1.26 1.96 2.00 2.03 2.68 3.06 4.32	CRN 300 UNITS MFG BEFORE 12/19/02 CRN 300 w/ OPTION F UNITS MFG BEFORE 12/19/02 CRN 300 CRN 300 w/ OPTION F CRN 400, 500 CRN 400, 500 w/ OPTION F CRN 600 CRN 600 w/ OPTION F CRN 750 CRN 750 w/ OPTION F CRN 1000, 1250, 1500 CRN 1000, 1250, 1500 w/ OPTION F CRN 1000, 1250, 1500 MFG 1/15/02 - 6/14/06 CRN 1000, 1250, 1500 w/ OPTION F CRN 1750, 2000, 2500, 3000 CRN 1750, 2000, 2500, 3000 w/ OPTION F CRN 1750, 2000, 2500, 3000 MFG 1/15/02 - 6/14/06	CRNМК7 CRNМК17 CRNМК8 CRNМК8 CRNМК10 CRNМК20 CRNМК10-5 CRNМК20 CRNМК11 CRNМК21 CRNМК11-5	SEE BELOW SEE BELOW SEE BELOW CRNМК25S CRNМК45S CRNМК26S CRNМК46S CRNМК27S CRNМК47S CRNМК28S CRNМК48S CRNМК29S CRNМК49S CRNМК29S CRNМК49S CRNМК30S CRNМК50S CRNМК30S
1000 1250 1500 1750 2000 2500 3000	1000 1250 1500 1750 2000 2500 3000	I-Controller Level 4	3" ANSI Flg. 4" ANSI Flg. 4" ANSI Flg. 6" ANSI Flg. 6" ANSI Flg. 6" ANSI Flg. 6" ANSI Flg.	85 85 85 85 85 85 85	49 49 49 55 55 55 55	41 51 51 60 60 60 60	1146 1521 1547 1940 1986 2315 2646	1173 1548 1574 1994 2040 2369 2700	208-230/3/60 460/3/60 575/3/60 575/3/60 380-420/3/50	6.3 7.29 9.47 11.3 11.5 15.0 19.7	CRN 600 CRN 600 w/ OPTION F CRN 750 CRN 750 w/ OPTION F CRN 1000, 1250, 1500 CRN 1000, 1250, 1500 w/ OPTION F CRN 1000, 1250, 1500 MFG 1/15/02 - 6/14/06 CRN 1000, 1250, 1500 w/ OPTION F CRN 1750, 2000, 2500, 3000 CRN 1750, 2000, 2500, 3000 w/ OPTION F CRN 1750, 2000, 2500, 3000 MFG 1/15/02 - 6/14/06	N/A N/A CRNМК9 CRNМК19 CRNМК10 CRNМК20 CRNМК10-5 CRNМК20 CRNМК11 CRNМК21 CRNМК11-5	CRNМК27S CRNМК47S CRNМК28S CRNМК48S CRNМК29S CRNМК49S CRNМК29S CRNМК49S CRNМК30S CRNМК50S CRNМК30S

TABLE 1 - Correction Factors (Multipliers) for Inlet Air Temperature and Pressure

INLET PRESSURE (PSIG)	INLET TEMPERATURE				
	80°F (27°C)	90°F (32°C)	100°F (38°C)	110°F (43°C)	130°F (54°C)
50	1.35	1.05	0.84	0.69	0.44
80	1.50	1.17	0.95	0.79	0.52
100	1.55	1.23	1.00	0.82	0.56
125	1.63	1.31	1.07	0.91	0.61
150	1.70	1.37	1.13	0.95	0.64
175	1.75	1.42	1.18	0.99	0.66
200	1.80	1.47	1.22	1.03	0.68

To adjust dryer capacity for conditions other than rated, use Correction Factors (multipliers) from Tables 1, 2 and 3.

Example: What is the capacity of a model CRN100 when the compressed air at the inlet dryer is at 150 psig and 100°F, the ambient temperature is 90°F and a 50°F dew point is desired?

Answer: 100 scfm (rated flow from Specifications Table) x 1.13 (correction factor for inlet temperature and pressure from Table 1) x 1.06 (correction factor for ambient temperature from Table 2) x 1.3 (correction factor for dew point from Table 3) = 156 scfm

TABLE 2 - Correction Factors for Ambient Temperature

AMBIENT TEMPERATURE	80°F (27°C)	90°F (32°C)	100°F (38°C)	110°F (43°C)
Multiplier	1.12	1.06	1.00	0.94

* Consult your local Distributor for information on complete maintenance kits
Refrigerant: CRN10-CRN750 use R-134a, models CRN1000-CRN3000 use R-404a
Maximum operating pressure: 250 PSIG for packages with I-Controller Level 1 & 2; 232 PSIG for packages with I-Controller Level 3 & 4
Maximum operating temperature: 130°F

- (1) Rated Flow Capacity - Conditions for rating dryers are in accordance with CAGI (Compressed Air and Gas Institute) Standard ADF100: Refrigerated Compressed Air Dryers - Methods for Testing and Rating. Conditions for rating above dryers are: compressed air at dryer inlet: 100 psig and 100°F saturated; ambient temperature: 100°F; operating on 60 Hz power supply. For dew point performance ratings, models RNC200-RNC1000, request a CAGI data sheet from your local distributor.
- (2) I-Controller Level 4 is standard on CRN1000-CRN3000
I-Controller Level 3 is available on CRN200-CRN750
I-Controller Level 2 is standard on CRN125-CRN750
I-Controller Level 1 is available on CRN25-CRN100
- (3) OD connection is tubing: NPT connections are male
- (4) Add 2 inches for Inlet/Outlet connections (does not apply to CRN10-CRN15 or CRN1000-CRN3000)

NOTES
(1) CSA and CE certified
(2) NEMA 1 standard

- a. An additional drain valve, consistent with type supplied with package I-Controller, is supplied when Cold Coalescing Oil Removal Filter option is specified.
- b. Units are air-cooled as standard. Contact your local Distributor if water-cooled versions are required.



1301 North Euclid Avenue
Princeton, Illinois 61356 USA
Phone 888/436-5499
Fax 815/872-0421
E-mail: Champion@championpneumatic.com
www.championpneumatic.com



Member

